

Elevate your expectations!



TIPTRAK

OVERVIEW

For over 45 years, TipTrak™ Bucket Elevators have defined the frontiers of gentle handling, low maintenance and spillage prevention.

Every TipTrak™ features a patented stainless-steel reinforced rubber chain which, once installed, never requires lubrication or tensioning. The utilization of rubber chain technology also significantly reduces noise.

The continuous interlocking bucket assembly running through the TipTrak™ offers smooth handling and prevents product damage, spillage, spillage-related hazards, clean-up and maintenance.

Three models, choice of carbon or stainless steel construction, and full customizability means that TipTrak™ can be made to perfectly suit each and every unique application and environment.

When it comes to continuous conveying and preventing material degradation, TipTrak™ is a must-have asset for long-term uptime and return on investment.

**NO PRODUCT
DEGRADATION**

NO SPILLAGE

HASSLE FREE

**NON-METALLIC BUCKET
ASSEMBLY**

MADE TO LAST



CAPACITY

UP TO 40 CU.FT./MIN

(depending on product characteristics)

MODELS

TIPTRAK OPEN TUBULAR

TIPTRAK PEC

TIPTRAK MONOCOQUE

CONFIGURATIONS

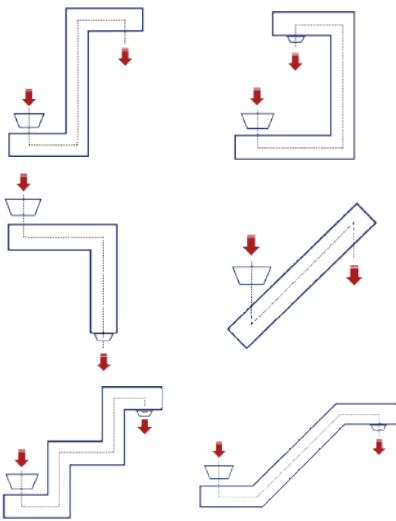

MATERIALS HANDLED

CHEMICAL, PLASTIC & RUBBER

- ADHESIVE
- AGRICULTURAL CHEMICALS
- ALUMINA
- AMMONIUM NITRATE
- BAKING SODA
- BATTERY MIX
- CARBON BLACK
- CATALYST
- CERAMIC SAND
- CHLORINE POWDER COMPOUND
- COATED SEEDS
- CRUMB RUBBER
- DETERGENT
- ETHYL CENTROLITE
- EXPLOSIVES
- FILTER CAKE
- GLASS MARBLES
- HERBICIDE
- IRON OXIDE
- MAGNESIUM FLUORIDE
- PHENOLIC RESIN FLAKE
- PIGMENT
- PLASTIC PELLETS
- RESINS
- RUBBER PELLETS
- SILICA GEL
- SILICONE POWDER
- SOAP POWDER
- SODA ASH
- SODIUM AZIDE
- SODIUM BOROHYDRIDE
- STABILIZER PASTILLES & FLAKES
- STEEL/IRON POWDER
- SULPHUR PASTILLES
- TALC POWDER
- TONER
- T.N.T.
- VICRON
- WAX FLAKES

FOOD PRODUCTS

- COFFEE - BEANS, GROUND, SOLUBLE
- CANDY - MOLDED
- CANDY PACKETS
- CHEWING GUM
- CHOCOLATE COVERED NUTS
- COUGH DROPS
- JELLY BEAN CENTERS
- FROZEN FRUIT
- VEGETABLES - FRESH & FROZEN
- FROZEN FRENCH FRIES
- CEREAL
- CEREAL FLAKES
- MINI PITA BREAD
- PACKAGED NOODLES
- SPICED BREAD CRUMBS
- FROZEN PASTA (IN BAGS)
- PET FOOD PELLETS
- POTATO CHIPS
- PEANUTS
- SNACK FOOD
- SOY PRODUCT
- RICE
- PASTA
- COOKIES
- FISH



TIPTRAK OPEN TUBULAR

The Open TipTrak™ offers at-a-glance monitoring, and easy cleaning access with a frame of square steel tubing (stainless or painted carbon steel). Personnel guarding and a multitude of other options allow for full customization of the equipment.



TIPTRAK MONOCOQUE

The Monocoque TipTrak™ features a fully sealed construction and is ready to operate in explosive, hazardous, and contamination-sensitive environments. This fully-customizable model can be gas-purged and subjected to positive or negative pressure.



TIPTRAK PEC

The PEC TipTrak™ is suitable for most applications and is our best-selling model. The enclosed design means that dust is contained and operators are protected. This fully-customizable unit is ready to handle your elevating and conveying challenges.



Did you know that UniTrak specializes in high-care solutions for our customers?

LEARN MORE AT: UNITRAK.COM/HIGH-CARE

Sanitary
Vertical
Belt Conveyor



KLEANTRAK

OVERVIEW

The KleanTrak conveyor from UniTrak is a cleated belt conveyor specifically engineered to overcome the challenges of sanitary conveying. These conveyors are designed to allow easy cleaning in food, pharmaceutical, and other washdown environments.

KleanTrak features a sanitary design which dramatically improves cleanability and minimizes the risk of pathogen or allergen contamination. KleanTrak conveyors use a cleated FDA-approved belt in a patented tensionless drive system which provides no belt slippage or stretch. Frames are made from 304 stainless steel and a variety of finishes are available, including electropolishing.

Each KleanTrak conveyor is equipped with a washdown duty drive motor and corrosion resistant bearings. Conveyors can elevate from 15° to 90°, and available options include a stationary base with leveling feet, or portable base assembly.

**FDA-APPROVED
SANITARY BELT**

**OPEN DESIGN FOR FAST &
EASY CLEANING**

**MINIMAL HORIZONTAL
SURFACES**

EASY TO SANITIZE IN-PLACE

**WASHDOWN DUTY MOTOR &
CORROSION RESISTANT
BEARINGS**



DESIGN PARAMETERS

- Maximum height: 40 feet (12 meters)
- Width: up to 24" (600 mm)
- Temperature: -30°F to +212°F
(-34°C to +100°C)
- Capacity up to 40 cubic feet (1 cubic meter) per hour
- All stainless steel with sealed, corrosion resistant bearings
- Washdown duty motor
- Tool-free disassembly for easy cleaning access

BELT

- Belt is made from Polyurethane
- Meets FDA regulation – 21 CFR 177.2600 & meets EU 1935/2004/EC
- Available in blue, white and natural
- Corrugated sidewalls for product containment
- Variety of cleats and scoops available
- Resistant to most cleaning materials (consult factory for full list)
- Available as an endless belt or laced

Belt Styles

- Flat top - matte finish
- Embedded diamond top – superior product release
- NubTop™ - provides “grip” or “release” characteristics for difficult products

AVAILABLE OPTIONS

- Portable / mobile base
- Removable personnel guarding
- Infeed and discharge chutes
- CIP system / drain pans
- Tilting mechanism
- Controls package

MATERIALS HANDLED

- | | |
|-----------------------------------|-----------------------|
| • COFFEE - BEANS, GROUND, SOLUBLE | • NOODLES |
| • CANDY - MOLDED | • SPICED BREAD CRUMBS |
| • CHEWING GUM | • PET FOOD |
| • CHOCOLATE COVERED NUTS | • POTATO CHIPS |
| • COUGH DROPS | • PEANUTS |
| • JELLY BEAN CENTERS | • NUTS |
| • FROZEN FRUIT | • SNACK FOOD |
| • VEGETABLES - FRESH & FROZEN | • SOY PRODUCT |
| • FROZEN FRENCH FRIES | • RICE |
| • CEREAL | • PASTA SHAPES |
| • CEREAL FLAKES | • COOKIES |
| | • FISH, SHRIMP |



Did you know that UniTrak specializes in high-care solutions for our customers?

LEARN MORE AT: UNITRAK.COM/HIGH-CARE

SALES@UNITRAK.COM

TEL NA: 1.905.885.8168 UK: +44 (0) 1457 865038

*High Output
High Versatility
Low Horsepower*



POWDERFLIGHT **OVERVIEW**

For over 40 years, Powderflight conveyors have combined speed, reliability, flexibility and productivity to support your manufacturing processes. These advantages enable operational efficiency, and make Powderflight well suited to address the challenges associated with conveying materials such as powders, granules, pellets or flakes.

Powderflight aeromechanical conveyors operate on a simple principle. Within a steel tube, a wire rope with evenly spaced discs travels at high speed, running in sprockets at each end of the conveyor. As material is fed in, the air stream aerates or fluidizes it and carries it to the outlet, where it is discharged by centrifugal force.

DUST TIGHT

HIGH THROUGHPUT

SMALL FOOTPRINT

VERSATILE

IDEAL FOR MIXES & BLENDS

LOW ENERGY CONSUMPTION



CAPACITY

UP TO 25 CU.FT./MIN

(depending on product characteristics)

CONFIGURATIONS

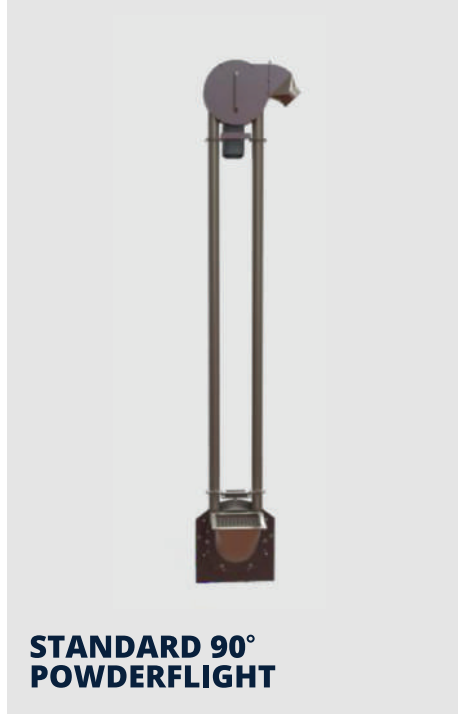
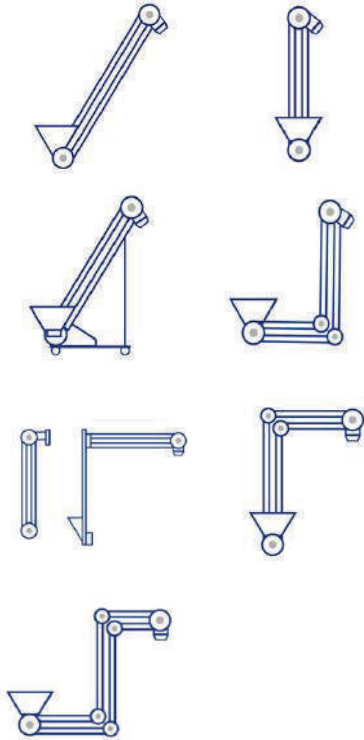

**STANDARD 90°
POWDERFLIGHT**



**STANDARD
HOPPER**



**SACK TIP / BAG
DUMP HOPPER**



**LARGE HOPPER
WITH DUST HOOD**



**PORTABLE/MOBILE
POWDERFLIGHT**



**LARGE HOPPER WITH
DUST HOOD & INTEGRAL
SCREW FEEDER**



**SMALL HOPPER
WITH LID/COVER**

MATERIALS HANDLED

- ADIPIC ACID
- ALUMINIUM CHLORIDE
- ALUMINIUM OXIDE
- ASBESTOS FINES
- BARYTES
- BENTONITE
- BRAN
- BROWN SUGAR
- CALCIUM CARBONATE
- CARBON BLACK
- CEMENT
- COFFEE BEANS
- COFFEE GROUNDS
- CROP SEEDS
- CURRY POWDER
- CUSTARD POWDER
- DEHYDRATED FOODS
- DETERGENT POWDERS
- DOG BISCUITS
- FLOCCULENTS
- GELATINE
- GRANULATED SUGAR
- GYPSUM
- ICING SUGAR
- IRON OXIDE
- LEAD OXIDE
- LEAD SHOT
- LIMESTONE POWDER
- MAGNESIUM OXIDE
- MELAMINE POWDER
- MILK POWDER
- MOULDING POWDER
- PERLITE
- PHTHALIC ANHYDRIDE
- PIGMENTS
- PLASTIC GRANULES
- POTATO FLOUR
- REFRACTORY POWDER
- RESINS
- SALT
- SAND
- SILICA
- SOAP GRANULES
- SODIUM SULPHATE
- SOYA FLOUR
- STARCH
- STERILIZING POWDER
- SUGAR BEET PULP DUST
- TALCUM POWDER
- TILE DUST
- TITANIUM DIOXIDE
- TOBACCO FINES
- UREA PRILLS
- WATER TREATMENT POWDERS
- WHEAT FLOUR
- YEAST EXTRACT
- ZINC OXIDE
- ZIRCONIUM SAND



TUBE CUTAWAY



**POWDERFLIGHT
ROPE**

*Flexible
Cost Effective
Small Footprint*



UNIFLEX

OVERVIEW

Providing durability and reliability to a wide range of applications, the UniFlex flexible auger is a simple yet rugged conveyor with only one moving part.

This versatile equipment is capable of transporting a wide range of free-flowing powders, granules, or small pellets, safely and reliably anywhere in your plant.

UniFlex conveyors easily integrate with a vast array of upstream and downstream equipment types.

SMALL & FLEXIBLE

TROUBLE-FREE

RELIABLE

DUST TIGHT

STOP & GO

CUSTOMIZABLE



CAPACITY

UP TO 6 CU.FT./MIN

(depending on product characteristics)

MODELS

UNIFLEX

EASY CLEAN

CONFIGURATIONS

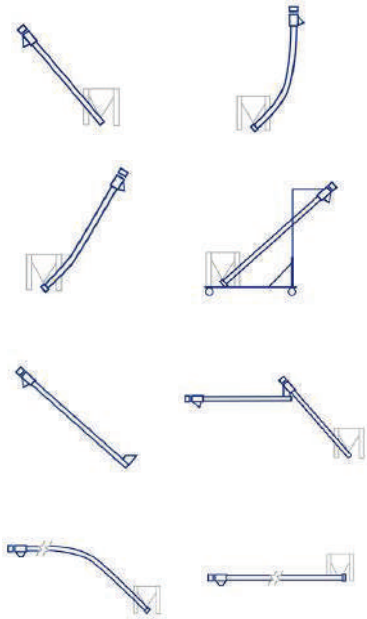

MATERIALS HANDLED

NON-FOOD

- ALUMINA OXIDE
- BENTONITE
- CALCIUM CARBONATE
- CEMENT
- DETERGENT POWDER
- FERTILIZER
- HERBICIDE
- LIGNIN POWDER
- NEOPENTYL GLYCOL
- PLASTIC PELLETS
- POLYSTYRENE BEADS
- POTASH
- SAND
- SODIUM METABISULPHITE
- STARCH
- TSP
- UREA
- ZINC OXIDE

FOOD

- ANIMAL FEED SUPPLEMENT
- BREAD CRUMBS
- CHICK PEAS, LENTILS
- COFFEE
- CORN STARCH
- FLAX
- FLOUR
- GRANULATED GARLIC
- GUAR POWDER
- MUSTARD SEED
- PEANUTS
- PROTEIN POWDER
- RICE PASTA
- STARCH
- SPICE BLENDS
- SUGAR
- VEGETABLES - DEHYDRATED
- WHEAT FLOUR



UNIFLEX



EASY CLEAN



Did you know that UniTrak specializes in high-care solutions for our customers?

LEARN MORE AT: UNITRAK.COM/HIGH-CARE

Simple
Sanitary
Cost Effective



EASY-CLEAN UNIFLEX OVERVIEW

The Easy-Clean UniFlex auger/screw conveyor is a simple, but ruggedly designed conveyor. This versatile piece of equipment is capable of transporting a wide range of free flowing powders, granules, or small pellets safely and reliably. It features rounded corners for ease of cleaning and is totally fabricated from type 304 stainless steel.

Easy-Clean UniFlex conveyors easily integrate with a vast array of upstream and downstream equipment. The Easy-Clean UniFlex conveyor is comprised of two main sections, a fixed lower portable base frame with 4 swivel casters, and an upper conveyor assembly.

The lower portable frame supports a bearing-shaft pivot system which allows the upper conveyor to be tilted down to a horizontal position. This upper conveyor assembly supports the infeed hopper, casing and drive / discharge assembly.

RELIABLE

PORTABLE

FOOD-GRADE

ONLY ONE MOVING PART

SIMPLE TOOL-FREE
DISASSEMBLY



CAPACITY

UP TO 6 CU.FT./MIN

(depending on product characteristics)

MATERIALS HANDLED

- ANIMAL FEED SUPPLEMENT
- BREAD CRUMBS
- CHICK PEAS, LENTILS
- COFFEE
- CORN STARCH
- FLAX
- FLOUR
- GRANULATED GARLIC
- GUAR POWDER
- MUSTARD SEED
- PEANUTS
- PROTEIN POWDER
- RICE PASTA
- STARCH
- SPICE BLENDS
- SUGAR
- VEGETABLES - DEHYDRATED
- WHEAT FLOUR

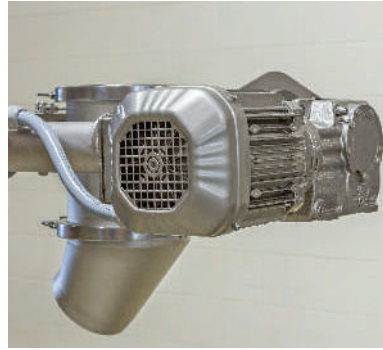

Sanitary stainless steel wash down gearmotor (OS4 protection)



Quick disassembly - fast reassembly - tool-less cleaning



Elimination of flat surfaces that can hold product



Casing - easily removed with tool-free T-handle clamps



Hopper corners are rounded for easy cleaning

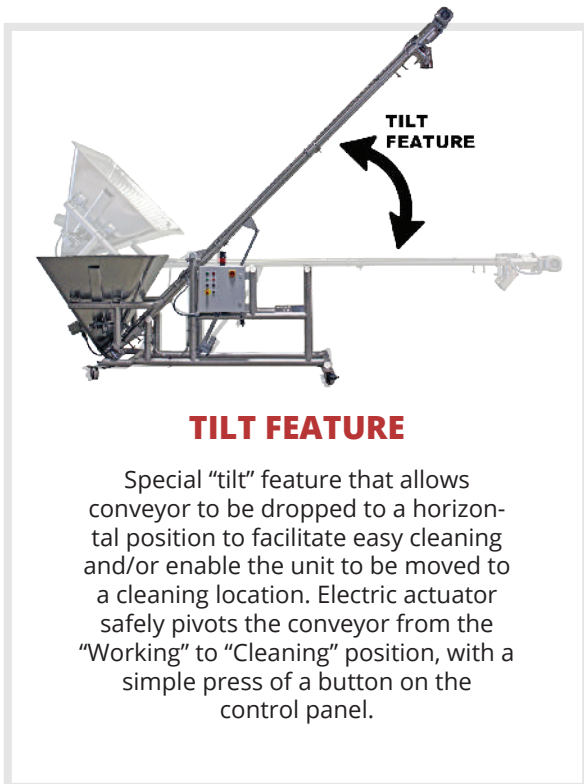

TILT FEATURE

Special "tilt" feature that allows conveyor to be dropped to a horizontal position to facilitate easy cleaning and/or enable the unit to be moved to a cleaning location. Electric actuator safely pivots the conveyor from the "Working" to "Cleaning" position, with a simple press of a button on the control panel.



Control panel - NEMA 4X



Bolted-in safety grate



Discharge chute & drive assembly



Auger casing - 3" or 5"; UHMW or stainless steel



Did you know that UniTrak specializes in high-care solutions for our customers?

LEARN MORE AT: UNITRAK.COM/HIGH-CARE

Simple
Safe
Effective



BAGSTANDER BULK BAG DISCHARGERS OVERVIEW

Emptying bulk bags doesn't have to be a dirty, dusty and unsafe job. Bagstander bulk bag dischargers enable the complete emptying of large bags and Flexible Intermediate Bulk Containers (FIBC). The adjustable upper frame will accommodate bags of varying sizes. Your operators will be protected from the risk of injury during the bulk bag emptying.

MODELS

FORK TRUCK

TOWER/HOIST

BULK BAG SIZES HANDLED

- For bulk bags up to 66" tall
- Customized units are available for taller bags

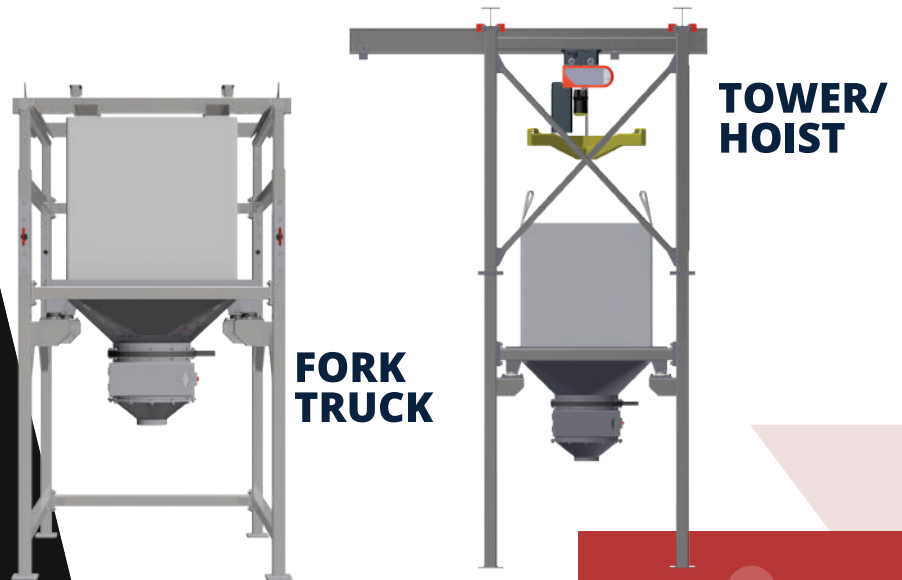

SAFE

STRONG

EASY TO USE

DUST FREE

SALES@UNITRAK.COM

TEL NA: 1.905.885.8168 UK: +44 (0) 1457 865038



Did you know that
UniTrak specializes in
high-care solutions
for our customers?

LEARN MORE AT: [UNITRAK.COM/HIGH-CARE](https://www.unitrak.com/high-care)

Simple
Safe
Effective



BAGSTANDER BULK BAG FILLER OVERVIEW

Bulk bag fillers allow simple and easy filling of dry, free-flowing materials into FIBC bulk bags. Our Bulk Bag Fillers minimize dust and can be connected directly to your dust collection system. For operations requiring bulk bag filling in various locations in the facility, our Fort Truck model provides portability and convenience. Ensure safe, clean, consistent bulk bag filling with a UniTrak Bulk Bag Filler.

MODELS

FORK TRUCK

FLOOR MODEL

BULK BAG SIZES HANDLED

- Std Bag Filler - bags from 39" to 72" tall
- Customized units are available for taller bags

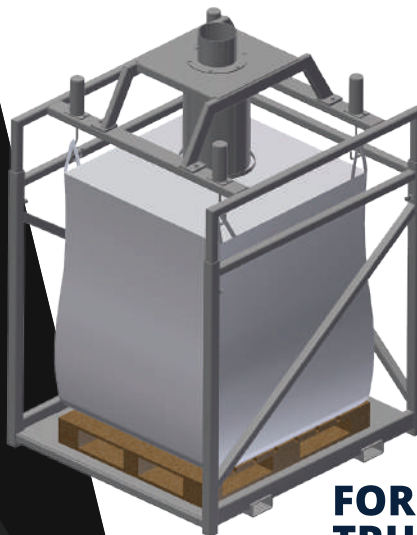

**FORK
TRUCK**

FLOOR MODEL



SAFE

STRONG

CLEAN

CONVENIENT



Did you know that UniTrak specializes in high-care solutions for our customers?

SALES@UNITRAK.COM
TEL NA: 1.905.885.8168 UK: +44 (0) 1457 865038